

# Agilent Technologies

E5810A LAN/GPIB Gateway for Windows

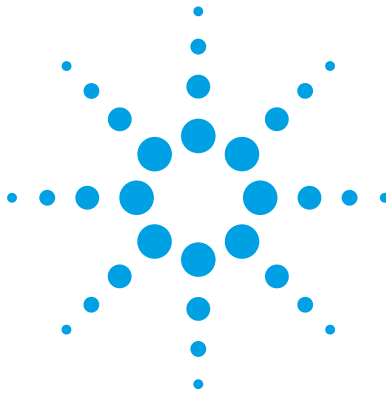

## ***Rack Mount Installation Note***

*One rack mount kit contains the hardware to mount a single E5810A or two E5810As, side-by-side.*

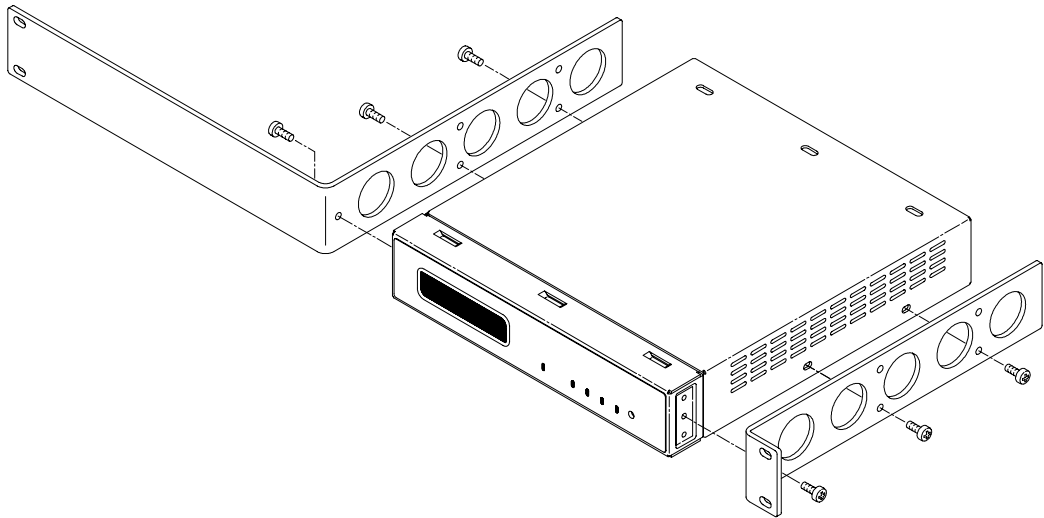

**Agilent Technologies**

**Rack Mounting One E5810 (see other side to rack mount two E5810s)**

**Parts needed to install a single E5810 in a rack:**

<b>A</b>	E5810-00021	Rack Ear - Full Rack	1	<b>D</b>	0515-1577	Screw - Machine	4
<b>B</b>	E5810-00022	Rack Ear - Half Rack	1	<b>E</b>	0590-0804	Nut, Machine	4
<b>C</b>	0515-1114	Screw, Panhead, M4x10	6				

- ① Remove both rubber bumpers from the E5810.

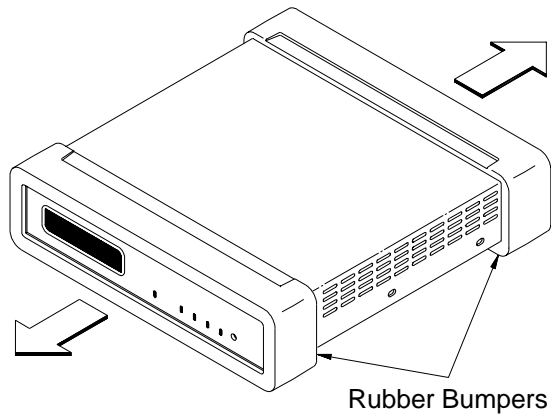

- ② Using Pozidriv screwdriver, attach Rack Ear-Half Rack (B) to the E5810 with three M4x10 Panhead Screws (C).
- ③ Using Pozidriv screwdriver, attach Rack Ear-Full Rack (A) to the E5810 with three M4x10 Panhead Screws (C).

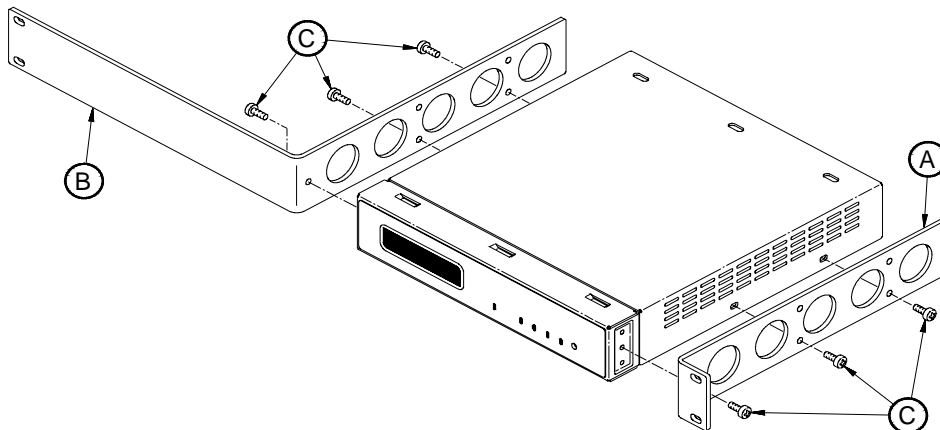

- ④ Connect GPIB and RS-232 cables. Plug AC Power cord into AC Power port on the E5810.

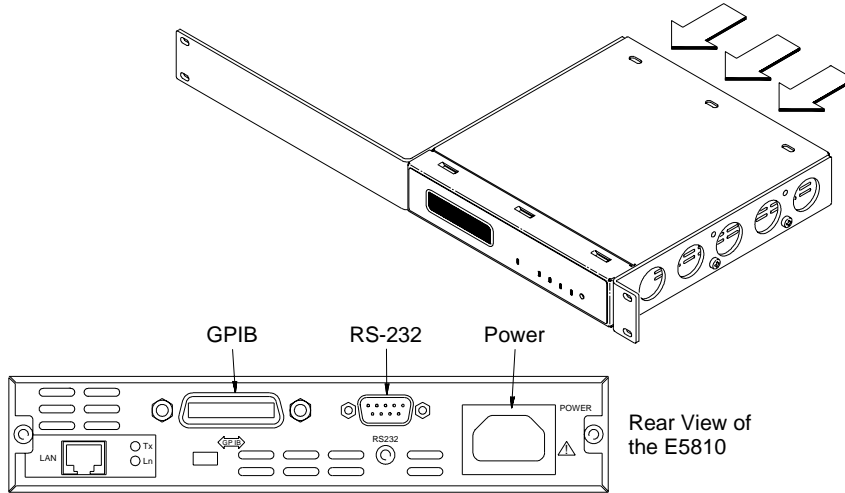

- ⑤ Using Phillips screwdriver, attach Rack Ears to rack with four Machine Screws (D) and four Machine Nuts (E).

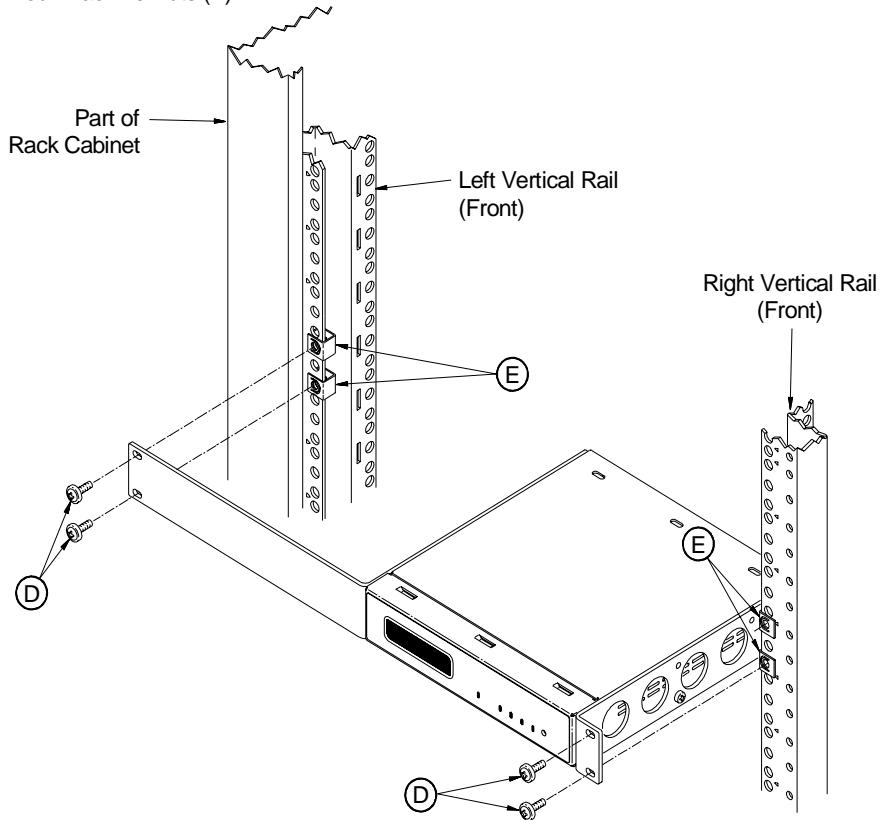

## Rack Mounting Two E5810s (see other side to rack mount one E5810)

### Parts needed to install two E5810s, side-by-side, in a rack:

<b>A</b>	0050-2166	Lock Link	2	<b>E</b>	0515-1577	Screw, Machine	4
<b>B</b>	E5810-00023	Bracket, Rear	1	<b>F</b>	0590-0804	Nut, Machine	4
<b>C</b>	E5810-00021	Rack Ear - Full Rack	2	<b>G</b>	0515-1367	Screw, Flathead, M4x8	2
<b>D</b>	0515-1114	Screw, Panhead, M4x10	6				

- ① Remove both rubber bumpers from the E5810.

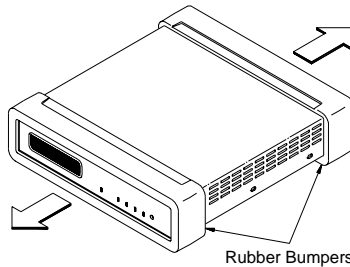

- ② Using Pozidriv screwdriver, install a Lock Link (A) on each E5810 with a Flathead Screw (G). Then, slide the two E5810s together so the Lock Links Interconnect. See Detail "A"
- ③ Using Pozidriv screwdriver, remove the screw at the rear of each E5810. Then, connect the Rear Bracket (B) to each E5810, using the screws you just removed.

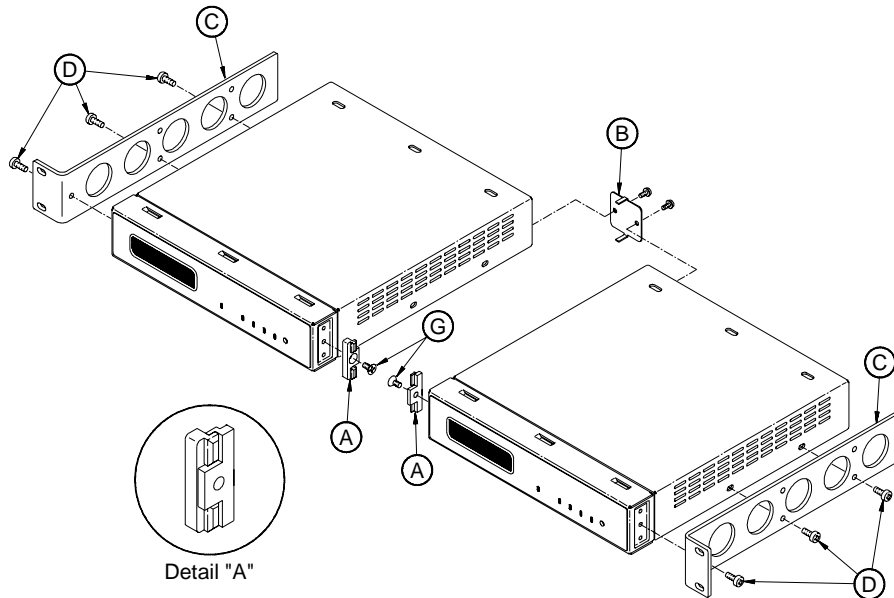

- ④ Using Pozidriv screwdriver, attach Rack Ear-Full Rack (C) to each E5810 with six M4x10 Panhead Screws (D).

- 5 Connect GPIB and RS-232 cables. Plug AC Power cord into AC Power port on the E5810s.

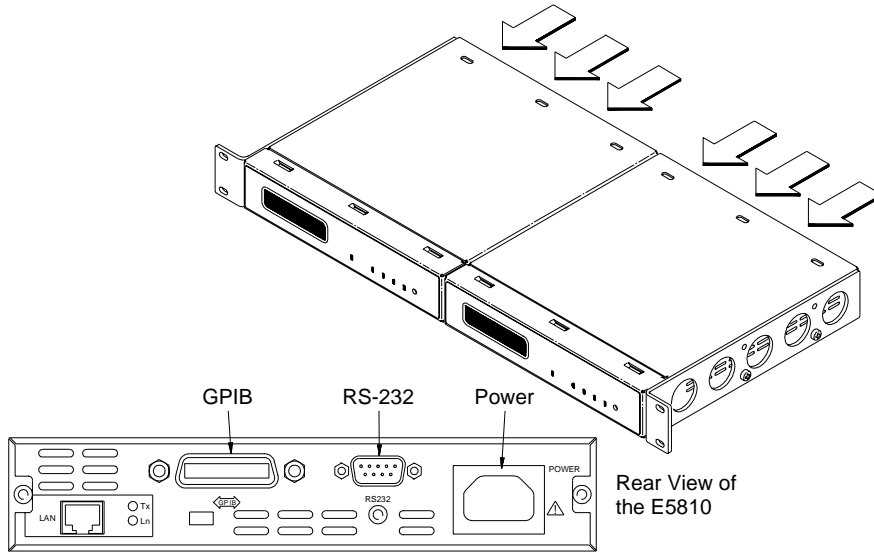

- 6 Using Phillips screwdriver, attach Rack Ears to rack with four Machine Screws (E) and four Machine Nuts (F).

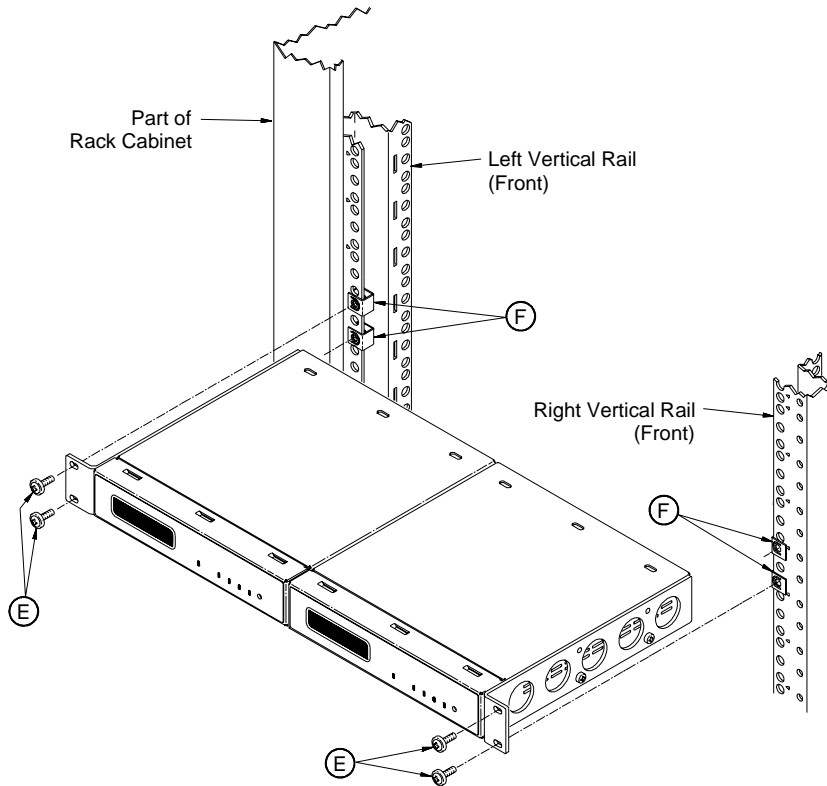

© Agilent Technologies, Inc. 2002, 2004



Part Number: E5810-99100  
Printed in Malaysia E0404 Apr 2004

